

# Battery Parallel Connection (Single-Phase Hybrid)

## **Disclaimer**

*The material in this document has been prepared by Sungrow Australia Group Pty. Ltd. ABN 76 168 258 679 and is intended as a guideline to assist solar installers for troubleshooting. It is not a statement or advice on any of the Electrical or Solar Industry standards or guidelines. Please observe all OH&S regulations when working on Sungrow equipment.*

## **Important information:**

In the Sungrow SH\*\*RS series, two stacks of batteries can be paralleled together.

The maximum number of modules in series is 6.

## **Process:**

If installing two stacks, it is best to install one stack only at first, then update all firmware on Dongle, inverter and battery, then connect the other battery.

## **DC power:**

Switch both batteries off at the MCB.

Using the MC4Evo2 'Y' connectors, connect both positives into one connector, and both negatives into the other connector.

Then connect the Positive and Negative to the inverter.

(Please note that this is a parallel connection between battery and inverter i.e. Positive to positive and negative to negative).

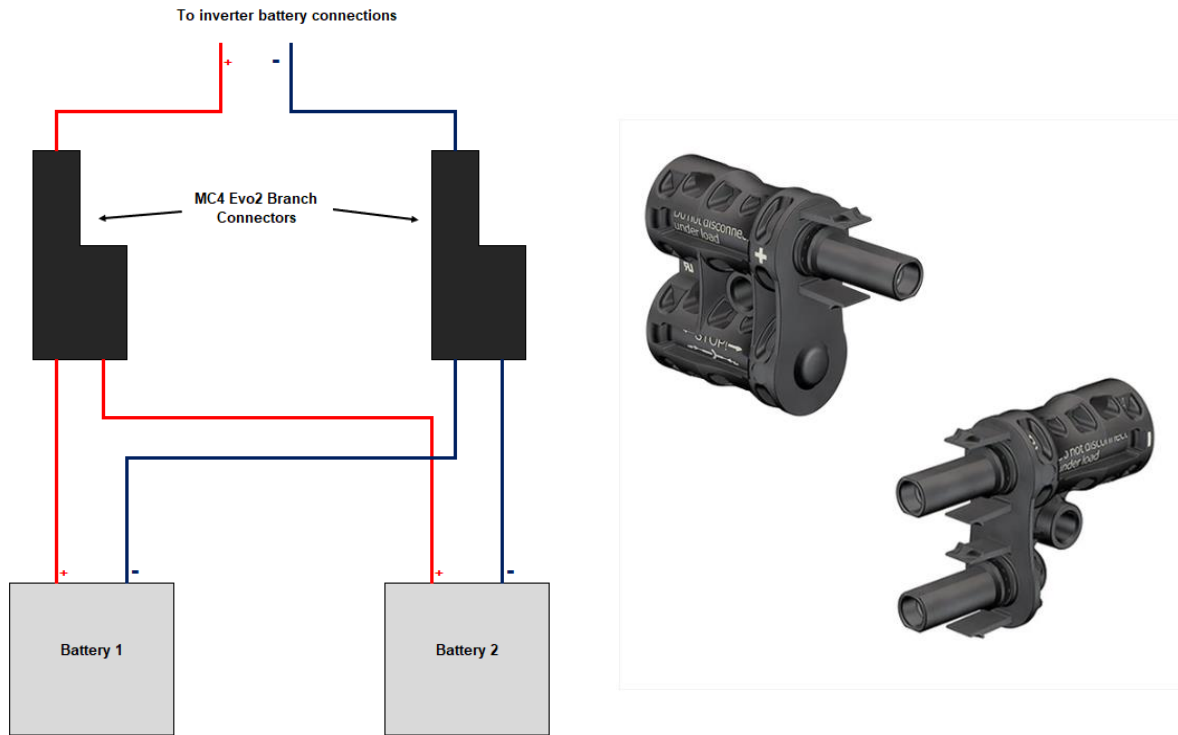

Pictures 1 & 2 showing 'Y' connectors to parallel the DC power

**CAN wiring:**

Next, prepare the CAN connector cables and connect in the fashion shown below.

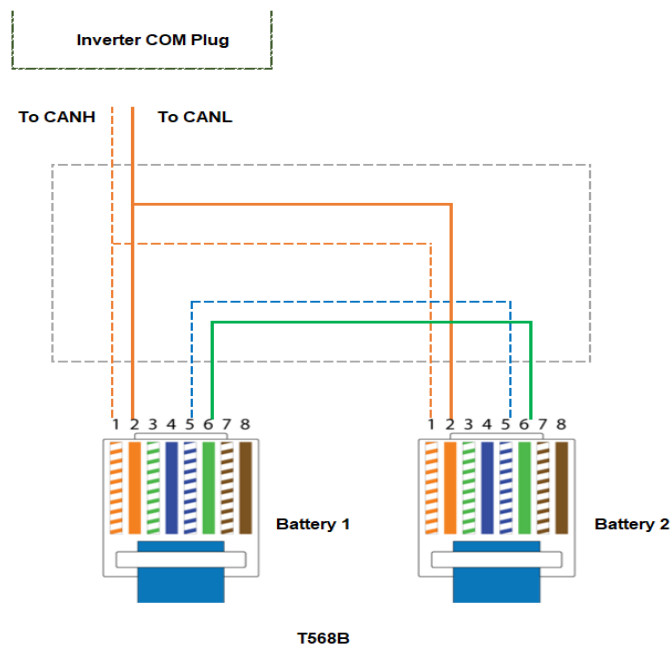

Picture 3 – CAN Parallel connection

CANH pin 1 of the RJ45 (T568B), White/Orange both connect in parallel and then connect to the CANH terminal in the inverter COM plug.

CANL pin 2 of the RJ45, Orange both connect in parallel and then to the CANL terminal in the inverter COM plug.

Pin 5 of the RJ45, White/Blue short between each battery.

Pin 6 of the RJ45, Green short between each battery.

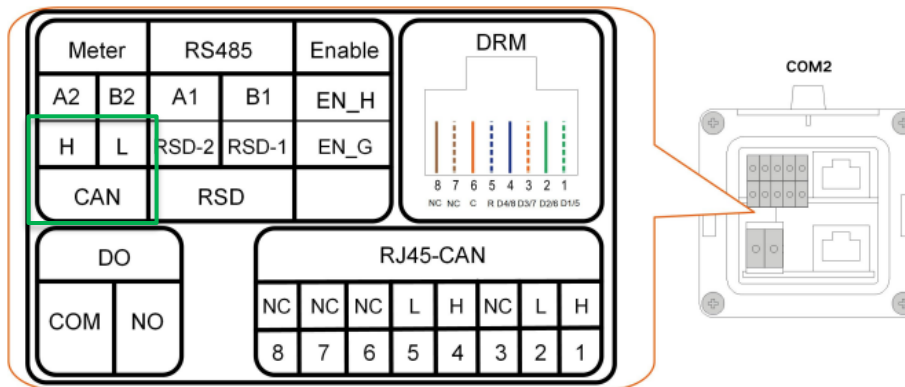

Picture 4 – CANH and CANL terminals on an SH5.0RS

The supplied light blue bootlace crimps MUST be used to connect tot the green com plug.

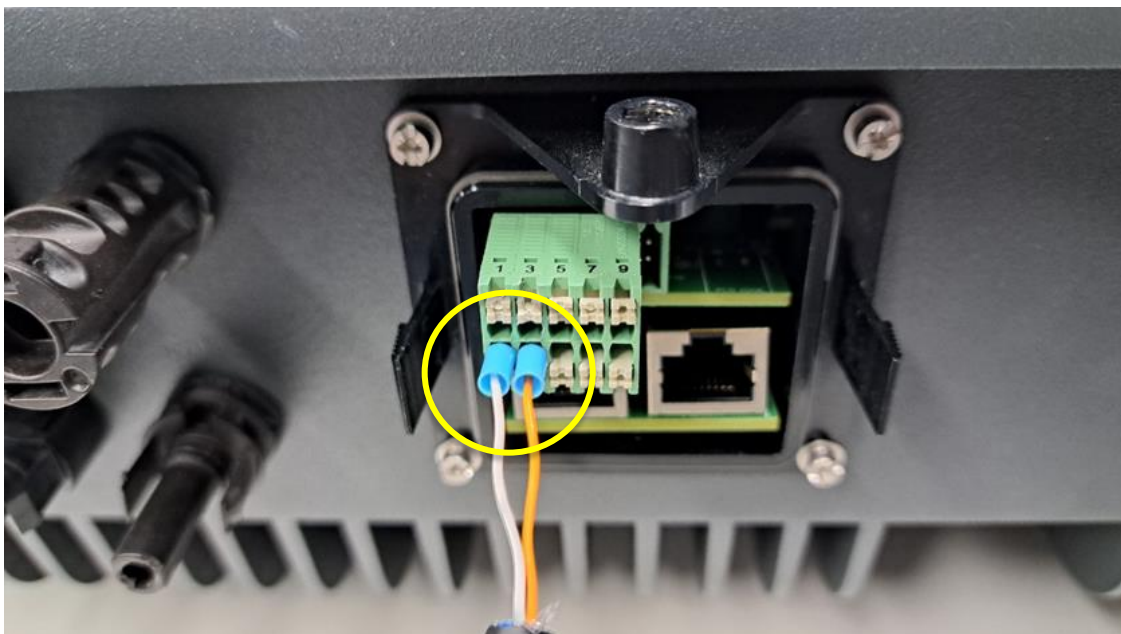

Picture 5 – Correct termination to avoid communication errors.

**Weatherproofing and protection:**

Gel filled connectors or WAGO connectors are suitable, and the join should be enclosed in a weatherproof junction box.



Ensure to fully lock the IP rated RJ45 into position by using the tool provided. You will feel a secure 'lock'.



Ensure the CAN cable connector is fully in the 'lock' position by using the supplied tool



**Earthing:**

Ensure to earth each battery as per AS/NZS3000 etc.

**iSolarCloud:**

Check on iSolarCloud to make sure both batteries are showing in the plant.

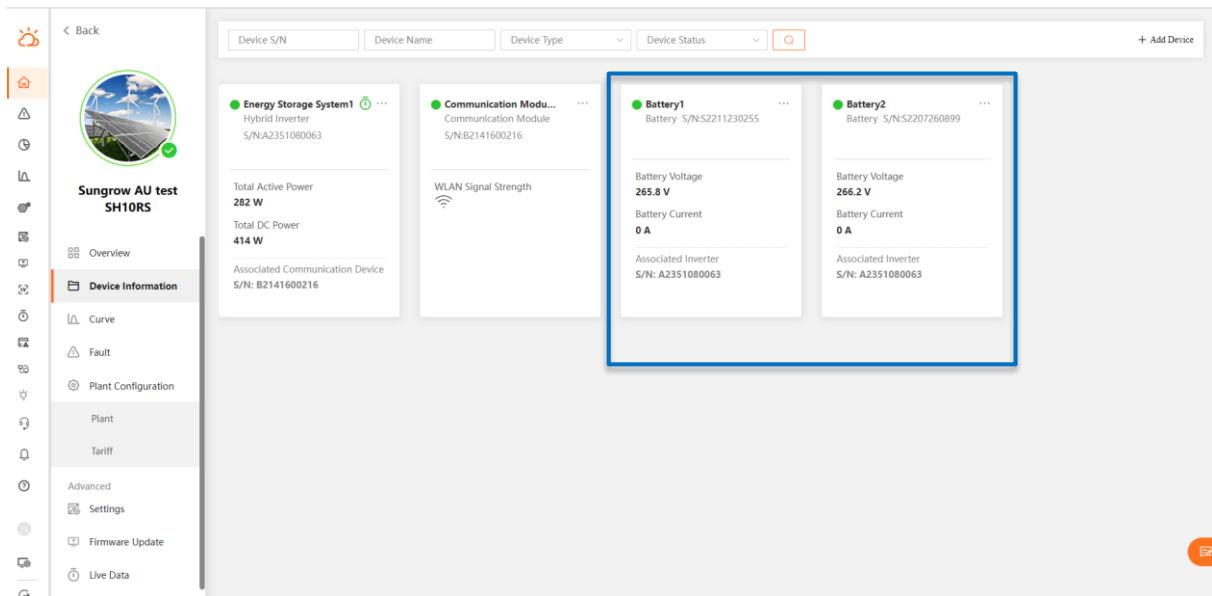

If the issue still persists, please take photos testing on site and contact Sungrow Service Department on 1800 786 476 or email to [service@sungrowpower.com.au](mailto:service@sungrowpower.com.au).