

Sungrow SBR HV Battery Installation Quick Guide

- SHRS series

Sungrow has released high-voltage battery - SBR series (9.6kWh-25.6kWh). Only **SBR096-SBR192** compatible to SHRS series.

To ensure smooth installation and avoid difficulty on site, please read below checklists and make sure you are ready before installing SBR HV batteries. If you have any questions, please free to contact Sungrow team (**1800 SUNGROW (786 476) service@sungrowpower.com.au**) before asking help onsite to reduce urgency.

Check Items	Requirements	Confirm?
Manuals	<ul style="list-style-type: none"> Read Sungrow product manuals before the installation. Follow the manuals and make sure the operating environment is suitable for inverter and batteries. 	
Application	<ul style="list-style-type: none"> Check with the distributors or Sungrow team for technical advice of off-grid application or any other complex scenarios (click here) Battery parallel application will not be available until Q3 2021 and the exact date is to be informed by Sungrow. 	
Remote Support	<ul style="list-style-type: none"> If it is the first installation of HV battery system, Sungrow advises installers to book the time for remote support. Our team will deliver support when you are on site to avoid any difficult to reach us. 	
Remote Area	<ul style="list-style-type: none"> Installers need to be cautious for the remote installation. Installer must take responsibility of the after-sales service. Sungrow technical support will be limited if the battery systems are installed remote areas with no local electrician for service (click here for remote area policy) 	
Internet	<ul style="list-style-type: none"> The system needs to operate with Internet available. otherwise, Sungrow's support will be limited and less efficient. If there is no Internet connection, please contact the distributors to purchase 4G dongle for internet access. 	
Cables/Tools	Prepare tools and cables prior to the installation. <ul style="list-style-type: none"> DC power cables \geq 11AWG (DC_{max}=30A, 6mm² recommended) with the insulation compliant to Australia Standard. Earth cables \geq 13AWG (4mm² recommended) Tools to make Ethernet cable with RJ45 terminal. The latest version of iSolarCloud is necessary to be installed on mobile or tablet prior to the commissioning and firmware upgrading. 	
Comm. Cable	<ul style="list-style-type: none"> Long cables (>10 m) could cause communication failure between the inverter and battery. It's installer's responsibility to conduct communication cable continuity test before contacting Sungrow team 	
Tips	<ul style="list-style-type: none"> Follow the installation tips & commissioning tips from the 2nd page of this document 	

Sungrow SBR HV Battery Installation Tips

Installation requirements:

Sungrow recommends that the shaded side of the building would be better to prevent the battery from exposure to the sun, rain, and snow. **Battery must not be mounted in direct sunlight as this affects the internal heat, and therefore efficiency of the battery and warranty.**



Minimum clearances:

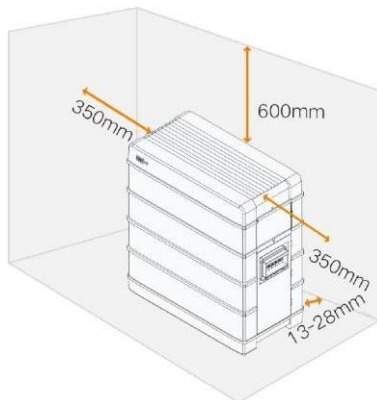

Installation process - SBR128 (4 modules) as an example

1. Screw feet in (Optional and available from Q4 2021).

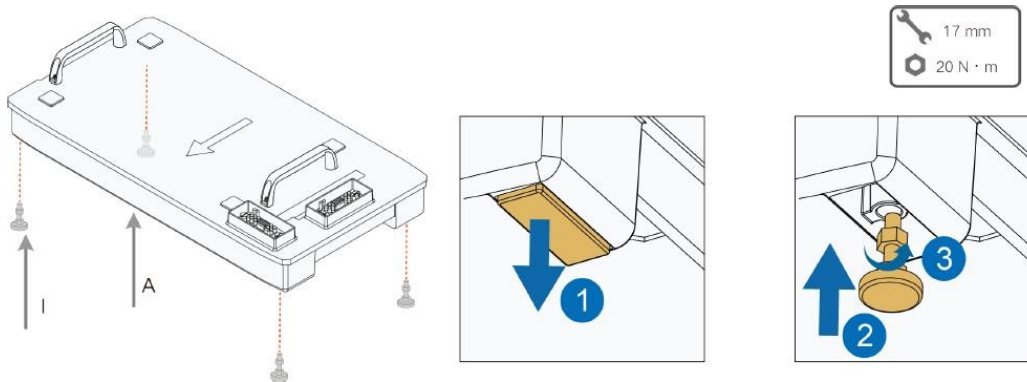

2. Place the base at the acceptable position in right way (arrows outward).

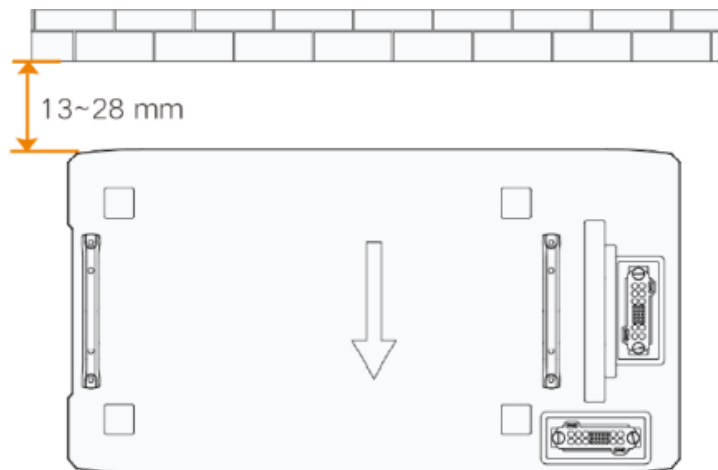

3. Stack up battery modules.

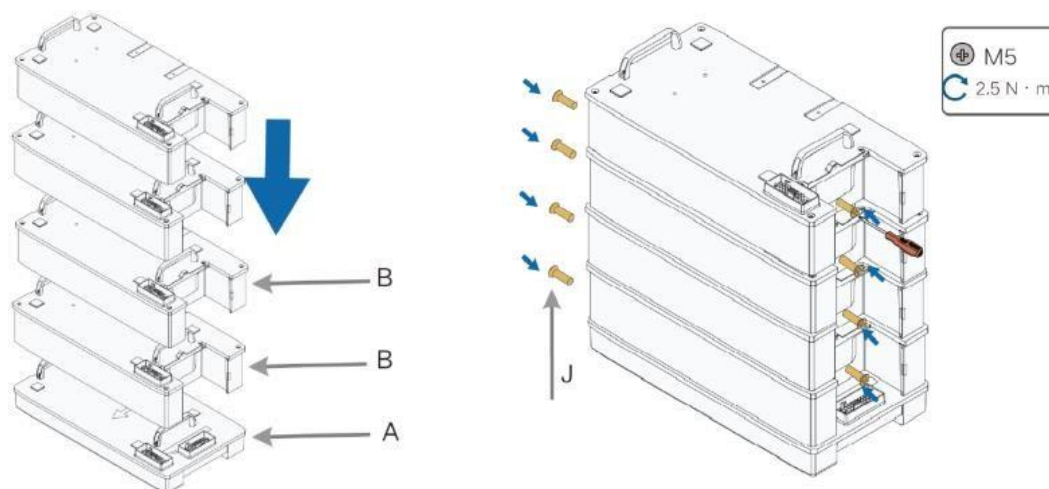

4. Insert BMU (make sure the DC MCB is off) and screw in.

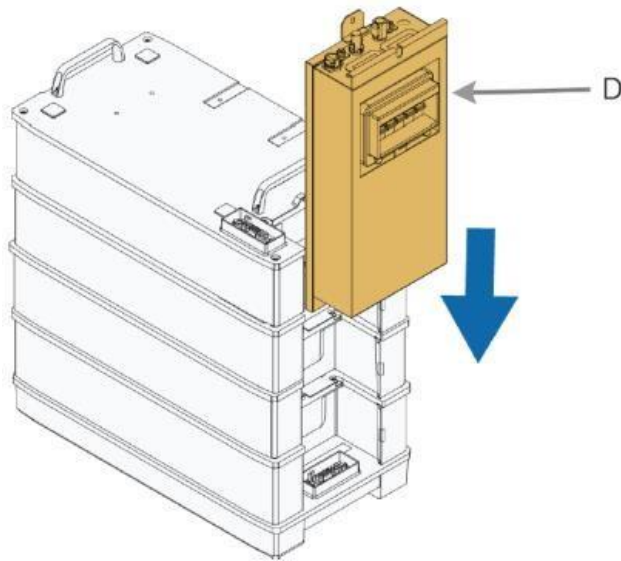

5. Apply L-bracket to fix the battery to the wall.

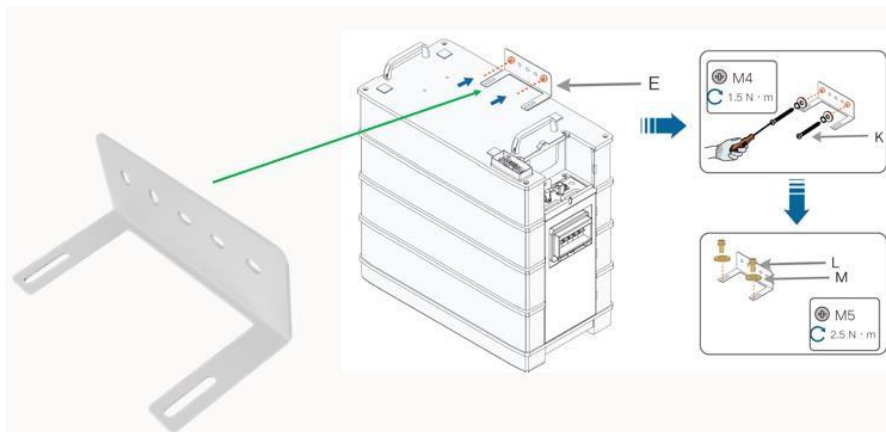

6. Cable's plug-in and wiring

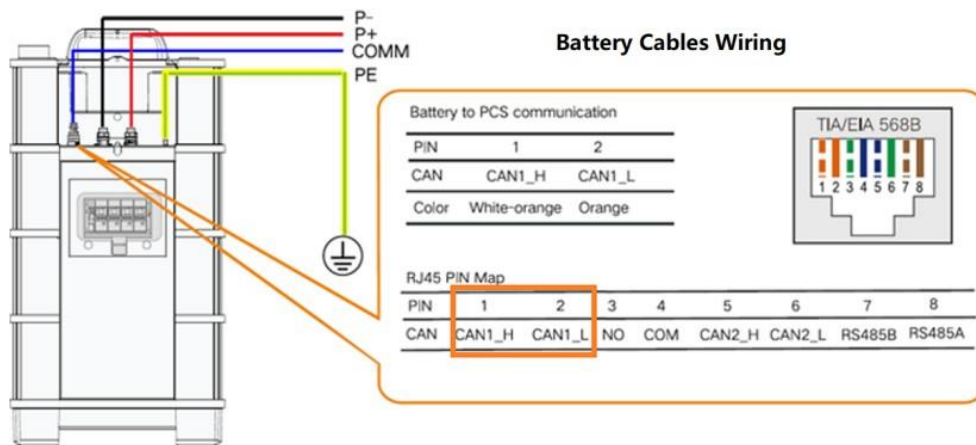

6-1. DC cables

Two DC cables (6mm²) need to be prepared by installers with Sunclix connectors. **One cable must have the same type of terminals at both ends** to make sure positive-to-positive & negative-to-negative connection.

6-2. Earthing

Green & Yellow earth cable (4mm²) needs to be prepared by installers.

6-3. COMM cable (Example of Sungrow COMM cable)

Sungrow provides battery COMM cable with 568B type, **using White-Orange cable for CAN_H, Orange cable for CAN_L**

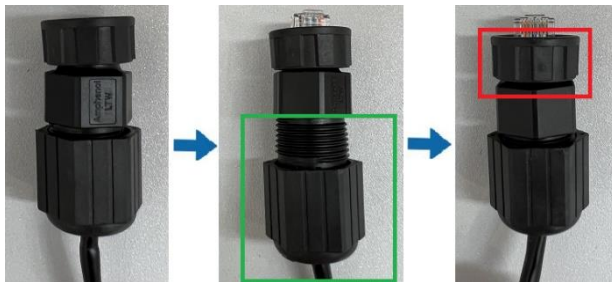

COMM Connection on battery side

Twist and loosen the green part and **push the cable out as much as possible**. Then fix the green part.

Twist and loosen the red part, plug the terminal into battery COMM port and then screw in to make sure the cable cannot be pulled out.

COMM connection on inverter side

Method 1. Standard cable provided by Sungrow connected to COM 2 (green plug)

- Pin 1&3 are for smart meters
- Pin 2&4 are for battery's CAN connection

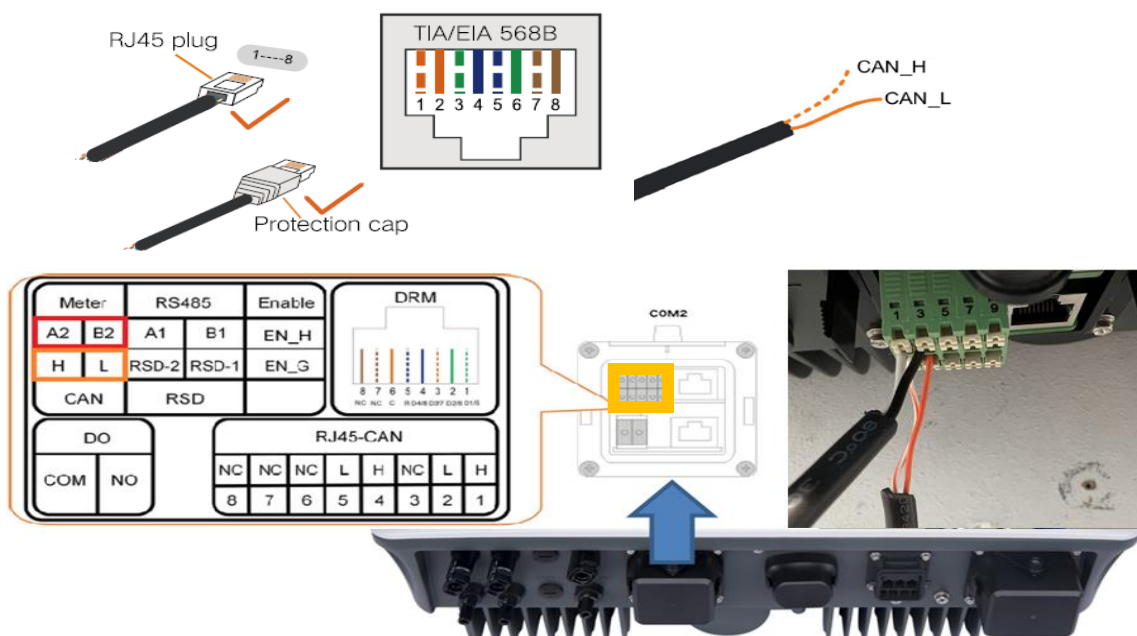

Method 2. self-made RJ45 port plugging into inverter

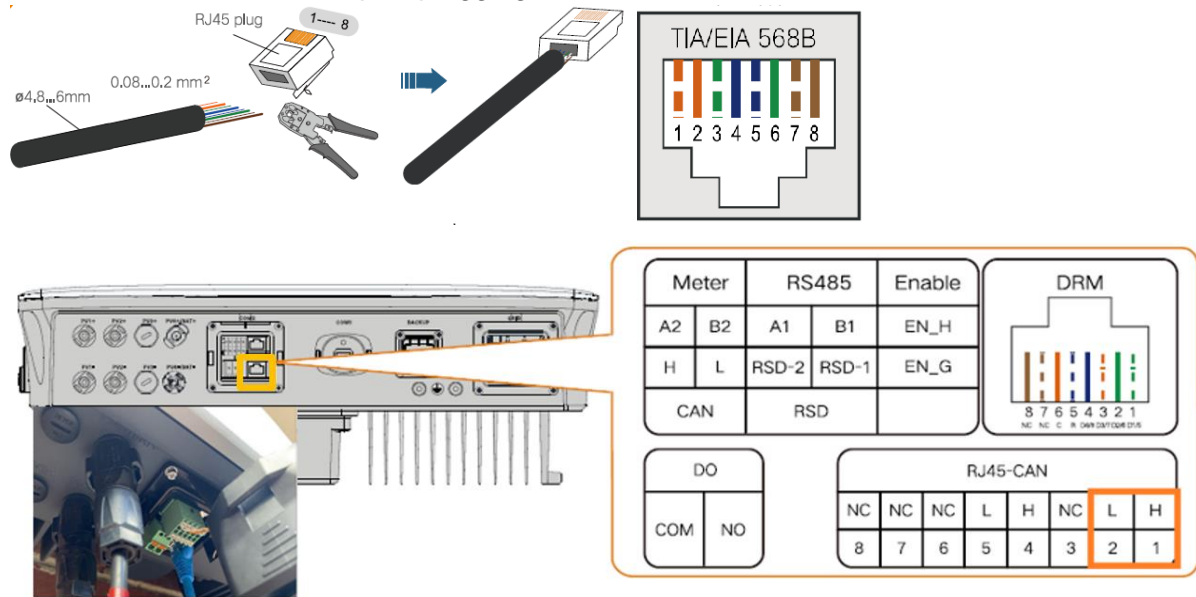

7. Put on the lid and fix it with the Stud 'H'.

Note: Directly use the Stud 'H' fix the lid, breaker module and the battery if the battery is **SBR096 (3 modules)**.

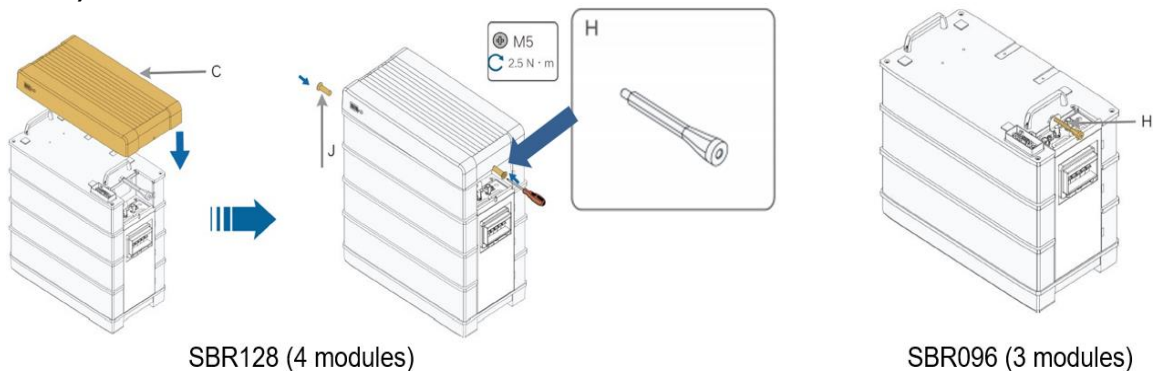

8. Put on the front cover

- The battery with 3 modules (SBR096) does not need the cover.
- The battery with 4 modules (SBR128) needs 1 front cover;
- The battery with 5 modules (SBR160) needs 2 front covers;
- The battery with 6 modules (SBR192) needs 3 front covers;

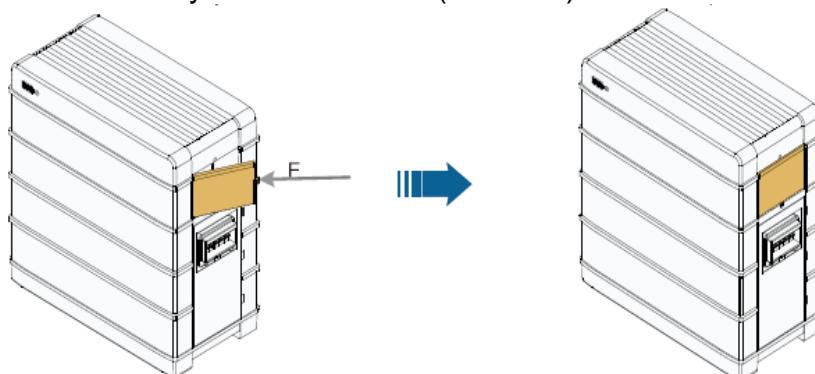

9. A completed installation is shown below.



Sungrow SBR HV Battery Commissioning Tips

Procedures	Details
1. Create the plant on iSolarCloud	<ul style="list-style-type: none"> • Complete the WiFi configuration and put the system online (click here). • Complete the system settings and grid settings. • If the system keeps 'under commissioning' for more than 15min, please contact Sungrow service team.
2. Battery Inspection	<ul style="list-style-type: none"> • Make sure the battery is fixed to the wall and not shakable. • Make sure 4 cables (mentioned above) are correctly connected. • Turn on the battery's circuit breaker to check if the indicator is on.
3. Communication check via local access	<p>Using iSolarcloud to get into local access with the following account and password and then see the system diagram (click here).</p> <p>Account: admin Password: pw8888</p> <div style="text-align: center;">  </div> <ul style="list-style-type: none"> • Wait for the compulsory firmware upgrade if there is. • Tap the battery icon to see if the key parameters are observable – e.g. voltage, SOC, SOH and etc.
4. Battery Settings via local access	<ul style="list-style-type: none"> • Go to 'More'- 'Setting' – 'System Parameters' to check the system information. • Go to 'More'- 'Setting' – 'Battery Parameters' to set SOC upper and lower limit if needed (5%-100%by default). • Go to 'More'- 'Setting' – 'Energy Management Parameters' to set charge/ discharge time if needed. • Go to 'More'- 'Setting' – 'Operation Parameters' - 'Off-grid Parameters' to turn on 'Backup Mode' if needed.
5. Quick test (optional)	<ul style="list-style-type: none"> • Usually if the power flow is visible in the local access, the system should operate normally. • Optional battery forced Charge/Discharge Test can be conducted by following the Step 3 & 4 – Go to 'More'- 'Setting' – 'Energy Management Parameters' – General – Change 'Self-consumption mode' into 'Compulsory mode' – set charge/discharge power 1-3 kW • Back to homepage to see if the power flow in/out the battery.
6. Other issue	<ul style="list-style-type: none"> • If there is the communication problem, please firstly check the COM connection between battery and inverter. • Regarding to the issue at inverter side, please firstly do the firmware upgrade (locally) or contact Sungrow service team's help.

Contact Sungrow team (1800 SUNGROW (786 476) service@sungrowpower.com.au) if needed.