

Backup AC Wiring Guide (Error 015) for 3-Phase Hybrid Inverters

Disclaimer

The material in this document has been prepared by Sungrow Australia Group Pty. Ltd. ABN 76 168 258 679 and is intended as a guideline to assist solar installers for troubleshooting. It is not a statement or advice on any of the Electrical or Solar Industry standards or guidelines. Please observe all OH&S regulations when working on Sungrow equipment.

Important!

Ensure the AC wiring conforms to the user manual. Otherwise, Any other wiring configuration may cause error 015 (Grounding cable fault).

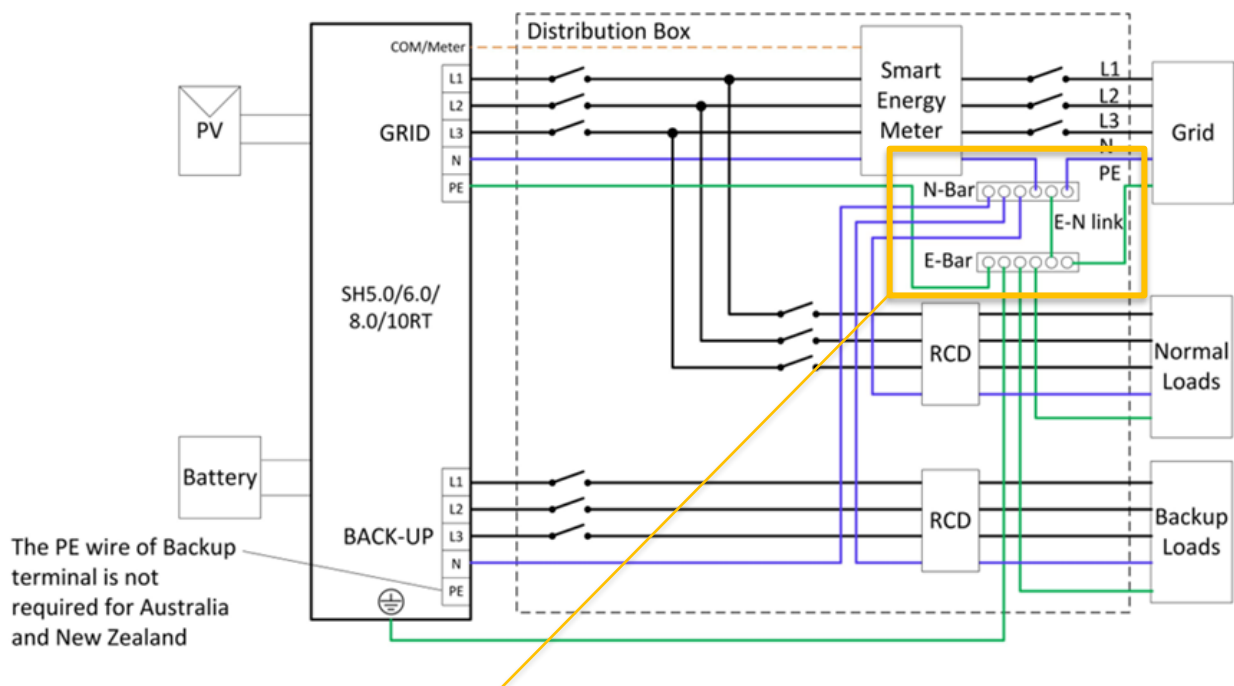

Both the Neutral and Earth connection from the Backup output must be connected to the Earth and Neutral bar in the main switchboard and must be connected to the M.E.N. link.

RCD's must comply with AS/NZS3000.

If the issue persists after following above procedures, please take photos testing on site and contact Sungrow Service Department on 1800 786 476 or email to service@sungrowpower.com.au, Monday- Friday 9am - 5pm (AEDT).